

## LEACHING OF ZINC AND COPPER FROM BLAST FURNACE DUST OF COPPER PRODUCTION OF SECONDARY RAW MATERIALS

*Oráč D., Hlucháňová B., Havlík T., Miškufová A., Petrániková M.*

*Technical University of Kosice, Faculty of Metallurgy, Department of Non-Ferrous Metals and Waste Treatment, Centre of Waste Processing, Letna 9, 042 00 Kosice, Slovak Republic*

*E-mail: dusan.orac@tuke.sk, www.censo.sk*

## LÚHOVANIE ZINKU A MEDI ZO ŠACHTOVÝCH ÚLETOV Z VÝROBY MEDI Z DRUHOTNÝCH SUROVÍN

*Oráč D., Hlucháňová B., Havlík T., Miškufová A., Petrániková M.*

*Technická univerzita v Košiciach, Hutnícka fakulta, Katedra neželezných kovov a spracovania odpadov, Centrum spracovania odpadov, Letná 9, 042 00 Košice, Slovensko*

*E-mail: dusan.orac@tuke.sk, www.censo.sk*

### Abstrakt

Táto práca sa zaoberá lúhovaním šachtových úletov, ktoré vznikli ako vedľajší produkt pri výrobe čiernej medi z druhotných surovín s cieľom vylúhovať kovy zinok a meď. Úlety pochádzajú zo spoločnosti KOVOHUTY, a.s. v Krompachoch. Počas experimentov sa sledoval vplyv teploty, koncentrácie kyseliny sírovej a navážky. Na experimenty lúhovania sa použili rôzne teploty (20, 40, 60 a 80 °C), koncentrácie kyseliny sírovodíkovej (0.25, 0.5, 1 a 2M) a rôzne pomery kvapalnej ku pevnej fáze (L:S = 10, 20 a 40). Z dosiahnutých výsledkov možno konštatovať, že lúhovanie zinku prebieha rýchlo a už v 5 minúte sa dosahujú vysoké výťažnosti a pri niektorých podmienkach sa vylúhuje prakticky všetok zinok. Lúhovanie medi však bolo odlišné. Najvyššie výťažnosti sa dosahovali až po 60 minútach a tendencia kriviek naznačuje, že predĺženie doby lúhovania by mohlo viesť k zvýšeniu výťažností medi do roztoku. Z výsledkov ďalej vyplýva, že pri určitých podmienkach (0.25M H<sub>2</sub>SO<sub>4</sub>, 90 °C a L:S = 20) je možné dosiahnuť stav, kedy sa bude selektívne lúhovať zinok (výťažnosť zinku nad 90 %) bez toho aby sa lúhovala meď (výťažnosť medi pod 1 %). Opačný stav t.j. kedy by sa dosiahli vysoké výťažnosti medi bez toho aby do roztoku prešiel zinok, nie je možné dosiahnuť. Najvyššie výťažnosti oboch kovov súčasne (97 % Zn a 68 % Cu) je možné dosiahnuť pri podmienkach: 2M H<sub>2</sub>SO<sub>4</sub>, 90 °C a L:S = 40.

### Abstract

The leaching of zinc and copper from blast furnace dust generated in pyrometallurgical treatment of secondary raw material originated in copper smelter KOVOHUTY, a.s., Krompachy, Slovakia is studied in this work. The influence of temperature, sulphuric acid concentration and weight of sample were investigated. For the experiments were used different temperatures (20, 40, 60 and 80 °C), concentrations of sulphuric acid (0.25, 0.5, 1 and 2M) and liquid to solid ratios (L:S = 10, 20 and 40). It follows from the results that leaching of zinc is fast and in the fifth minute was reached high extractions and under certain conditions practically the zinc was totally dissolved. Copper leaching had different behavior. The highest extractions were achieved after 60 minutes and the tendencies of curves indicate that prolongation of leaching time could result in higher extractions. The results also reveal that at

certain conditions (0.25M H<sub>2</sub>SO<sub>4</sub>, 90 °C and L:S = 20) zinc can be dissolved selectively from copper but opposite situation where only copper is leached out without leaching of zinc can not be reached. Highest extractions for both metals together (97 % Zn and 68 % Cu) can be reached at conditions 2M H<sub>2</sub>SO<sub>4</sub>, 90 °C and L:S = 40.

**Keywords:** blast furnace dust, leaching, zinc, copper, secondary raw materials, hydrometallurgy

## 1. Introduction

Industrial wastes belong to category of hazardous waste due to their amount and also the content of substances which are taken as hazardous. Relatively high amount of such waste is generated by metallurgy. These wastes are in solid form (e.g. slag, dust), liquid form (waste water, sludge) or gaseous phase (PCBs, organics, CO<sub>2</sub>). The dusts are generated in production of many metals and production of copper is one of them [1].

On the present, copper smelter KOVOHUTY, a.s., Krompachy, Slovakia is the only producer of technical-purity copper in Slovakia. In the past, this company produced a copper from primary sources by pyrometallurgical processes, but today they are producing the copper pyrometallurgically only from secondary raw materials (scrap) [2].

The dusts are generated in the shaft furnace as a by-product during the melting of copper scrap. According to Announcement of Slovak ministry of environment 284/2001 Z.z. these dusts are classified as a hazardous waste because of content of heavy non-ferrous metals and other components. On the other hand, it can be taken as the source of valuable metals like zinc, copper or lead [3, 4].

The chemical composition of this dust largely depends on composition of charged scrap. The average composition of dust is: 45 – 60 % Zn, 0.7 – 1.4 % Cu, 5.0 – 15.0 % Pb and 0.4 – 10.3 % Sn. The material charged to the shaft furnace, is low-grade copper material within the range 1 to 10 %. In the next steps, e.g. converting and pyrometallurgical refining, is treated the waste with higher content of copper [5].

Three groups of components present in dusts could be taken account according to their composition:

- Valuable components: Cu, Zn, Mn
- Slagging material: CaO, MgO, Al<sub>2</sub>O<sub>3</sub>, SiO<sub>2</sub>
- Accessory components: Fe, Pb, Ni, As and other [6]

The main component of the dust is zinc either in metallic form or in form of the oxide (ZnO), followed by the oxides of heavy non-ferrous metals (e.g. CuO, SnO<sub>2</sub>, Sb<sub>2</sub>O<sub>5</sub>). However, the lead is present not in oxide form, but in elemental form. It originated by reducing conditions in blast furnace [7].

It follows from above mentioned, that blast furnace dusts of secondary copper production are hazardous material, but on the other hand this material contains interesting amounts of valuable metals e.g. zinc, copper or lead.

The possible methods for treatment dusts are: pyrometallurgical, hydrometallurgical or combination of these two methods. This work studies the hydrometallurgical treatment of blast furnace dust from copper production of secondary raw materials with the aim to find optimum conditions to leaching of zinc and copper.

## 2. Experimental

### 2.1 Material

The blast furnace dusts of copper production of secondary raw materials were used for the experiments originated in copper smelter KOVOHUTY, a.s., in Krompachy, Slovakia. Total weight of material was 4.5 kg. The representative sample was obtained by automatic sample divider and chemically analyzed by AAS method, Tab. 1.

Table 1 Chemical composition of blast furnace dust

Element	Cu	Zn	Ni	Sb	Fe	Cd	Cl	Pb
Content [%]	1.06	46.14	0.02	0.016	0.02	0.21	0.05	23.79

### 2.2 Leaching

Leaching was realized in the apparatus, scheme of which is shown in Fig 1. Experiments were carried out in glass beaker immerse in water bath at 20 °C, 40 °C, 60 °C, and 90 °C with constant stirring. Four concentrations of sulphuric acid (0.25M, 0.5M, 1M, and 2M) were used as a leaching reagent. The volume of leaching reagent for each experiment was 200 ml and weight of sample was 5, 10 and 20 g what gives L:S ratio (liquid to solid phase) equal to 40, 20 and 10. Time of leaching was 60 minutes. The liquid samples were taken according to given time schedule at 5, 10, 15, 30 and 60 minutes. The samples were analyzed by AAS method for copper and zinc amount.

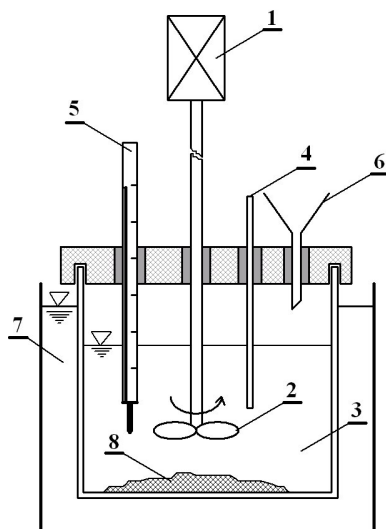

Fig.1 The scheme of the leaching apparatus (1 – stirrer engine; 2 – propeller; 3 – leaching pulp; 4 – sampler; 5 – thermometer; 6 – feeder; 7 – water thermostat; 8 – dust)

## 3. Results and discussion

### 3.1 The zinc extraction

Fig. 2 and 3 show kinetic curves of zinc leaching at various concentrations of sulphuric acid (0.25M, 0.5M, 1M and 2M) and temperatures 20 °C, 40 °C, 60 °C, and 90 °C.

The extractions of zinc at 90 °C are very high and at all concentrations are over 95 %. At other temperatures the extractions around 90 % were achieved, only at 0.25M H<sub>2</sub>SO<sub>4</sub> the

extractions were around 70 %. Practically all zinc was dissolved at 1M and 2M solution. The lowest zinc extractions were always achieved at 0.25M  $H_2SO_4$  and higher at 2M  $H_2SO_4$ . On the other hand, the differences between each concentration are not so large. As the graphs show, the leaching of zinc from the dust is very fast and extractions after 5 minutes reached the highest extractions. It is mainly given by large surface area of particles. However, the tendency of curves is decreasing what could be probably caused by formation of basic zinc sulphate ( $ZnSO_4 \cdot 3Zn(OH)_2 \cdot nH_2O$ ). This fact needs to be verifying by further investigation.

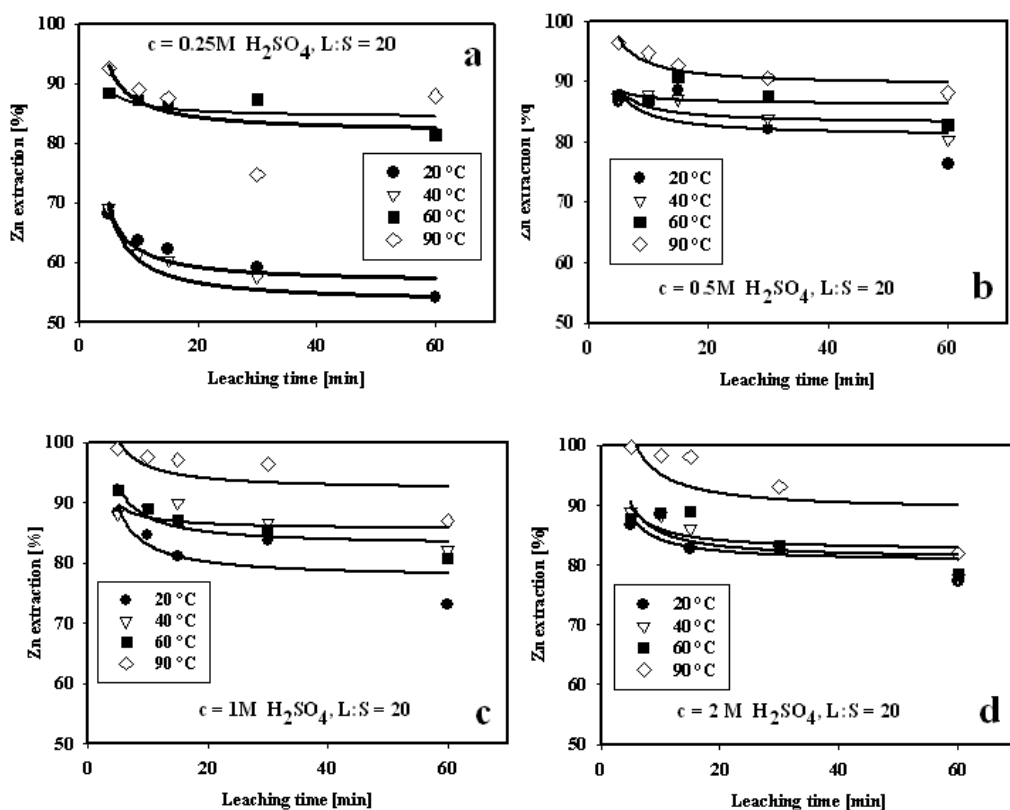

Fig.2 a – d Zinc extractions at various concentrations and temperatures with L:S = 20

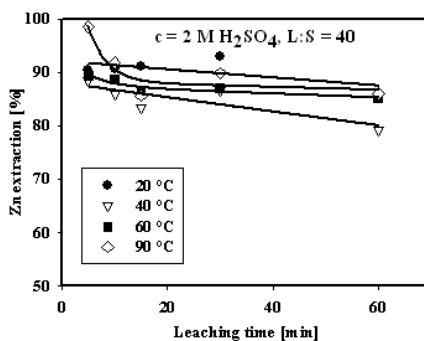

Fig.3 Zinc extractions at 2M  $H_2SO_4$ , various temperatures and with L:S = 40

### 3.2 The copper extraction

The best results of copper extraction was observed at L:S = 40. Kinetic curves of copper leaching in various concentrations of  $\text{H}_2\text{SO}_4$  and temperatures are shown in Fig. 4.

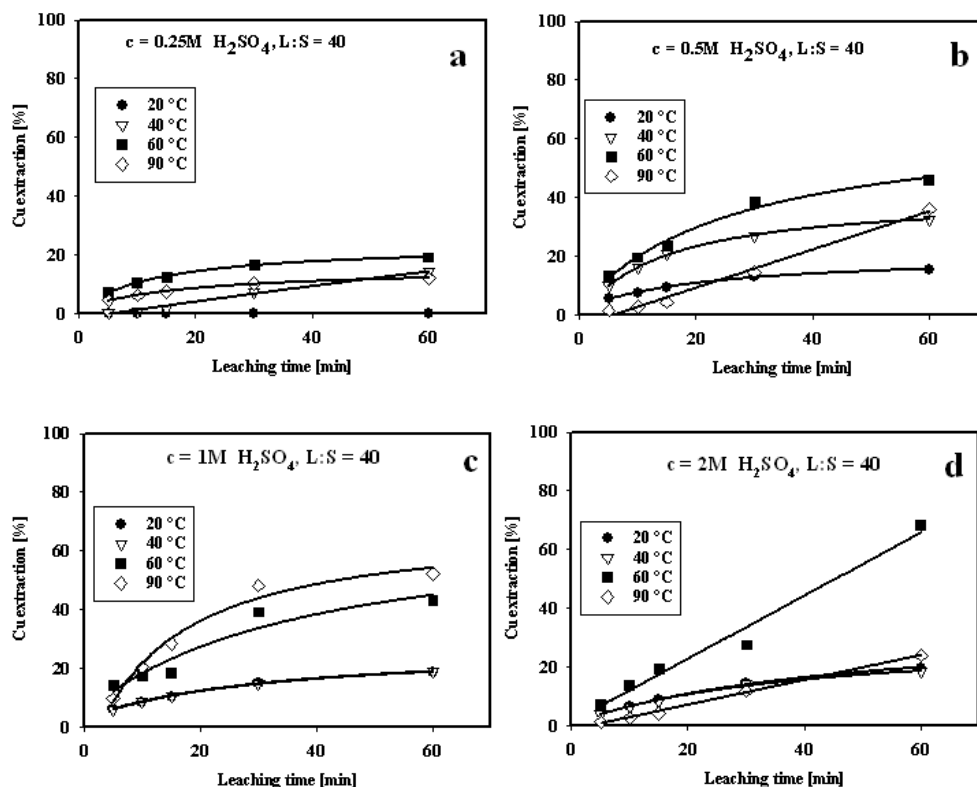

Fig.4 a – d Copper extractions at various concentrations and temperatures with L:S = 40

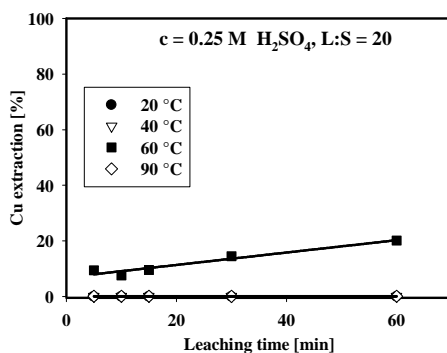

Fig.5 Copper extractions at  $0.25\text{M H}_2\text{SO}_4$ , various temperatures and with L:S = 20

The copper leaching has different behavior as in case of zinc. The higher extractions are achieved after 60 minutes; in zinc leaching it was in fifth minute, and the curves have

increasing tendency. Moreover, the results are not as high as in zinc, but the tendency of curves indicates that prolongation of time would result in higher extractions. The increasing of concentration and temperature has positive effect to copper leaching. However, the optimal copper extractions were achieved at 60 °C. The higher extraction (around 60 %) was achieved in 2M solution of sulphuric acid after 60 minutes at 60 °C. On the other hand, the lowest copper extraction (under 1 %) was achieved at concentration 0.25M H<sub>2</sub>SO<sub>4</sub>, L:S = 20 and temperature 90 °C (Fig. 5). At these conditions extraction of zinc is above 90 %, what gives good opportunity to selectively leach out zinc without leaching of copper.

#### 4. Conclusion

From the results of blast furnace dust leaching experiments with aim to leach zinc into solution follows:

- The highest zinc extractions were achieved at 2M H<sub>2</sub>SO<sub>4</sub> (for all L:S ratio), where practically all zinc was dissolved.
- At L:S = 20 the highest extraction were obtained.
- The differences in extractions between each concentration were not so large.
- The differences in extractions between each temperature were not so large.
- In all experiments was observed, that in fifth minute of leaching the extraction is above 60 % and at this time the higher extractions were achieved.
- The increasing of temperature has positive effect on kinetic of leaching, because at higher temperatures the higher extractions were achieved.

From the results of blast furnace dust leaching experiments with aim to leach copper into solution follows:

- Behavior of copper is different as in case of zinc.
- The higher copper extraction was not achieved under same conditions with zinc.
- The higher extraction (60 %) was achieved in 2M H<sub>2</sub>SO<sub>4</sub> at 60 °C with L:S = 40 (weight of sample 5 g) after 60 minutes.
- The combination of L:S = 40 and 60 °C looks to be suitable for copper leaching and gives higher extractions for all concentrations (it applies to chosen experimental conditions).
- The increasing temperature and concentration of sulphuric acid had positive effect on copper leaching.

The mentioned results describe achieved facts. However, the optimal conditions of leaching depend on fact, if we want to leach out selectively zinc, copper or we want to leach out both of these metals.

From the results also follows:

- At conditions (0.25M H<sub>2</sub>SO<sub>4</sub>, 90 °C, L:S = 20) can be achieved state at which extraction zinc is above 90 % and copper is under 1 %.
- Highest extractions of both metals (97 % Zn and 68 % Cu) can be together achieved at conditions 2M H<sub>2</sub>SO<sub>4</sub>, 90 °C, L:S = 40.
- It can not be achieved state where copper is leached maximally with no extraction of zinc.

#### Acknowledgement

*This work was supported by Ministry of Education of the Slovak republic under grant MŠ SR 1/0087/08. This contribution is the result of the project implementation Research*

*excellence centre on earth sources, extraction and treatment supported by the Research & Development Operational Programme funded by the ERDF, ITMS number: 26220120017.*

### **Literature**

- [1] Havlík T.: Spracovanie a detoxikácia odpadov, TU Košice, September 1996, ISBN 80-7099-286, s. 81- 85.
- [2] Kovohuty a. s., [cited 17.02.2009] On the internet: <<http://www.krompachy.sk>>
- [3] Výrobný program KOVOHÚT Krompachy a. s., [cited 21.11.2008] On the internet: <[http://www.krompachy.sk/portal/obsah/aktuality/prilohy/00200/ziadost\\_o\\_zmenu\\_ipkz.doc](http://www.krompachy.sk/portal/obsah/aktuality/prilohy/00200/ziadost_o_zmenu_ipkz.doc)>
- [4] Zbierka zákonov č. 284/2001, Vyhláška životného prostredia Slovenskej republiky z 11. júna 2001, ktorou sa ustanovuje Katalóg odpadov, čiastka 118, s. 3118
- [5] Hlucháčová B.: Diplomová práca: Možnosti spracovania úletov z pyrometalurgickej výroby medi, Košice 2009, s. 29
- [6] Ferencová M. Bakalárska práca: Termodynamické štúdium oceliarskych úletov, TU Košice 2006, s. 14 – 18.
- [7] Škrobián M. a kol.: Charakterization of flue dust from Cu alloy scarp melting in view of their hydrometallurgical treatment, Acta Metallurgica Slovaca, 10, 2004 Special Issue, s. 280 – 288.